

इंटरनेट

मानक

### Disclosure to Promote the Right To Information

Whereas the Parliament of India has set out to provide a practical regime of right to information for citizens to secure access to information under the control of public authorities, in order to promote transparency and accountability in the working of every public authority, and whereas the attached publication of the Bureau of Indian Standards is of particular interest to the public, particularly disadvantaged communities and those engaged in the pursuit of education and knowledge, the attached public safety standard is made available to promote the timely dissemination of this information in an accurate manner to the public.

“जानने का अधिकार, जीने का अधिकार”

Mazdoor Kisan Shakti Sangathan

“The Right to Information, The Right to Live”

“पुराने को छोड़ नये के तरफ”

Jawaharlal Nehru

“Step Out From the Old to the New”

IS/ISO 8528-1 (2005): Reciprocating Internal Combustion Engine Driven Alternating Current Generating Sets, Part 1: Application, Ratings and Performance [TED 2: Automotive Primemovers]



“ज्ञान से एक नये भारत का निर्माण”

Satyanarayan Gangaram Pitroda

“Invent a New India Using Knowledge”



“ज्ञान एक ऐसा खजाना है जो कभी चुराया नहीं जा सकता है”

Bhartrhari—Nitiśatakam

“Knowledge is such a treasure which cannot be stolen”



BLANK PAGE



भारतीय मानक  
प्रत्यागामी आंतरिक दहन इंजन चालित  
प्रत्यावर्ती धारा जनरेटिंग सेट  
भाग 1 अनुप्रयोग, रेटिंग एवं कार्यकारिता

*Indian Standard*

RECIPROCATING INTERNAL COMBUSTION  
ENGINE DRIVEN ALTERNATING CURRENT  
GENERATING SETS

PART 1 APPLICATION, RATINGS AND PERFORMANCE

ICS 27.020; 29.160.40

© BIS 2012

**BUREAU OF INDIAN STANDARDS**  
MANAK BHAVAN, 9 BAHADUR SHAH ZAFAR MARG  
NEW DELHI 110002

## NATIONAL FOREWORD

This Indian Standard (Part 1) which is identical with ISO 8528-1 : 2005 'Reciprocating internal combustion engine driven alternating current generating sets — Part 1: Application, ratings and performance' issued by the International Organization for Standardization (ISO) was adopted by the Bureau of Indian Standards on the recommendation of the Automotive Primemovers Transmission and Steering Systems and Internal Combustion Engines Sectional Committee and approval of the Transport Engineering Division Council.

The text of ISO Standard has been approved as suitable for publication as an Indian Standard without deviations. Certain conventions are, however, not identical to those used in Indian Standards. Attention is particularly drawn to the following:

- a) Wherever the words 'International Standard' appear referring to this standard, they should be read as 'Indian Standard'.
- b) Comma (,) has been used as a decimal marker while in Indian Standards, the current practice is to use a point (.) as the decimal marker.

This standard also makes a reference to the BIS Certification Marking. Details of which are given in National Annex A.

In this adopted standard, reference appears to certain International Standards for which Indian Standards also exist. The corresponding Indian Standards which are to be substituted in their respective places are listed below along with their degree of equivalence for the editions indicated:

<i>International Standard</i>	<i>Corresponding Indian Standard</i>	<i>Degree of Equivalence</i>
ISO 3046-1 Reciprocating internal combustion engines — Performance — Part 1: Declarations of power, fuel and lubricating oil consumptions and test methods — Additional requirements for engines for general use	IS 10000 (Part 4) : 1980 Methods of test for internal combustion engines: Part 4 Declarations of power, efficiency, fuel consumption and lubricating oil consumption	Technically Equivalent
ISO 8528-2 : 2005 Reciprocating internal combustion engine driven alternating current generating sets — Part 2 : Engines	IS/ISO 8528-2 : 2005 Reciprocating internal combustion engine driven alternating current generating sets: Part 2 Engines	Identical
ISO 8528-3 : 2005 Reciprocating internal combustion engine driven alternating current generating sets — Part 3: Alternating current generators for generating sets	IS/ISO 8528-3 : 2005 Reciprocating internal combustion engine driven alternating current generating sets: Part 3 Alternating current generators for generating sets	do
ISO 8528-4 : 2005 Reciprocating internal combustion engine driven alternating current generating sets — Part 4: Controlgear and switchgear	IS/ISO 8528-4 : 2005 Reciprocating internal combustion engine driven alternating current generating sets: Part 4 Controlgear and switchgear	do
ISO 8528-5 : 2005 Reciprocating internal combustion engine driven alternating current generating sets — Part 5: Generating sets	IS/ISO 8528-5 : 2005 Reciprocating internal combustion engine driven alternating current generating sets: Part 5 Generating sets	do

(Continued on third cover)

*Indian Standard*

# RECIPROCATING INTERNAL COMBUSTION ENGINE DRIVEN ALTERNATING CURRENT GENERATING SETS

## PART 1 APPLICATION, RATINGS AND PERFORMANCE

### 1 Scope

This part of ISO 8528 defines various classifications for the application, rating and performance of generating sets consisting of a Reciprocating Internal Combustion (RIC) engine, Alternating Current (a.c.) generator and any associated controlgear, switchgear and auxiliary equipment.

It applies to a.c. generating sets driven by RIC engines for land and marine use, excluding generating sets used on aircraft or to propel land vehicles and locomotives.

For some specific applications (e.g. essential hospital supplies, high-rise buildings) supplementary requirements may be necessary. The provisions of this part of ISO 8528 should be regarded as the basis for establishing any supplementary requirements.

For other reciprocating-type prime movers (e.g. sewage-gas engines, steam engines), the provisions of this part of ISO 8528 should be used as a basis for establishing these requirements.

Generating sets meeting the requirements of this International Standard are used to generate electrical power for continuous, peak-load and standby applications. The classifications laid down in this part of ISO 8528 are intended to help understanding between manufacturer and customer.

### 2 Normative references

The following referenced documents are indispensable for the application of this document. For dated references, only the edition cited applies. For undated references, the latest edition of the referenced document (including any amendments) applies.

ISO 3046-1, *Reciprocating internal combustion engines — Performance — Part 1: Declarations of power, fuel and lubricating oil consumptions, and test methods — Additional requirements for engines for general use*

ISO 8528-2<sup>2)</sup>, *Reciprocating internal combustion engine driven alternating current generating sets — Part 2: Engines*

ISO 8528-3<sup>2)</sup>, *Reciprocating internal combustion engine driven alternating current generating sets — Part 3: Alternating current generators for generating sets*

ISO 8528-4<sup>2)</sup>, *Reciprocating internal combustion engine driven alternating current generating sets — Part 4: Controlgear and switchgear*

ISO 8528-5<sup>2)</sup>, *Reciprocating internal combustion engine driven alternating current generating sets — Part 5: Generating sets*

---

2) ISO 8528-2, 3, 4 and 5 are all under revision.

### 3 Symbols and abbreviations

An explanation of the symbols and abbreviations used in this International Standard are shown in Table 1.

**Table 1 — Symbols and abbreviations**

Symbol or abbreviation	Term	Unit
$P$	Power	kW
$P_{pp}$	Permissible average power	kW
$P_{pa}$	Actual average power	kW
$p_r$	Total barometric pressure	kPa
$T_{or}$	Charge air coolant temperature	K
$T_r$	Air temperature	K
$t$	Time	s
$\varphi$	Power factor	
$\varnothing_r$	Relative humidity	%
a.c.	Alternating current	
COP	Continuous power	kW
PRP	Prime power	kW
LTP	Limited-time running power	kW
ESP	Emergency standby power	kW

### 4 Other regulations and additional requirements

For a.c. generating sets used onboard ships and offshore installations, which have to comply with rules of a classification society, the additional requirements of the classification society shall be observed. The classification society name shall be stated by the customer prior to placing the order.

For a.c. generating sets operating in non-classified equipment, any additional requirements are subject to agreement between the manufacturer and customer.

If special requirements from any other regulatory authority (e.g. inspecting and/or legislative authorities) have to be met, the authority name shall be stated by the customer prior to placing the order.

Any additional requirements shall be subject to agreement between the manufacturer and customer.

### 5 General description

#### 5.1 Generating set

##### 5.1.1 General

A generating set consists of one or more RIC engines used to produce mechanical energy and one or more generators to convert the mechanical energy into electrical energy. The generating set includes any components used for coupling the mechanical prime mover(s) and electrical generator(s) (e.g. couplings, gearbox) and, where applicable, any load-bearing and mounting components.



### 5.1.2 Prime movers

For the purposes of this International Standard, prime movers may be of two types:

- a) compression-ignition engines; and
- b) spark-ignition engines.

Depending on the generating set application, the following criteria, among others, may be important in selecting the prime mover to be used:

- a) quality of fuel and fuel consumption;
- b) exhaust gas and noise emission;
- c) speed range;
- d) mass and dimensions;
- e) sudden electrical loading and frequency behaviour;
- f) generator short-circuit characteristics;
- g) cooling systems;
- h) starting systems;
- i) maintenance requirements;
- j) waste heat utilization.

### 5.1.3 Electrical generators

For the purposes of this International Standard, electrical generators may be of two types:

- a) synchronous; and
- b) asynchronous.

Depending on the generating set application, the following criteria, among others, may be important in selecting the generator to be used:

- a) voltage characteristics during starting and normal operation as well as after load changes, taking into account the electrical power factor;
- b) short-circuit behaviour (electrical and mechanical);
- c) efficiency;
- d) generator design and enclosure type;
- e) parallel-operation behaviour;
- f) maintenance requirements.

### 5.1.4 Control and switchgear

Equipment for the control, switching, operation and monitoring of the generating set shall be part of the associated controlgear and switchgear systems.



### 5.1.5 Auxiliaries

Auxiliaries are items of equipment additional to those already fitted/installed on the generating set as supplied but essential to its proper and safe operation, such as:

- a) starting system;
- b) air intake and exhaust gas systems;
- c) cooling systems;
- d) lubricating oil system;
- e) fuel system (including fuel treatment where applicable);
- f) auxiliary electrical power supply.

## 5.2 Power Station

A power station comprises an installation of one or more generating sets and their auxiliary equipment, the associated controlgear and switchgear and, where applicable, the place of installation (e.g. a building, an enclosure or special equipment for protection from the weather).

## 6 Application criteria

### 6.1 Modes of operation

#### 6.1.1 General

The generating set mode of operation may affect certain important performance characteristics (e.g. its economical and reliable operation, the intervals between maintenance and repair) and shall be taken into account by the customer when agreeing the requirements with the manufacturer (see Clause 11).

#### 6.1.2 Continuous operation at constant load

Continuous operation at constant load is defined as operation of a generating set without time limit taking into account the maintenance period, where the applied electrical load is constant.

EXAMPLE Providing a base load for a combined heat and power plant.

#### 6.1.3 Continuous operation at varying load

Continuous operation at varying load is defined as operation of a generating set without time limit, taking into account the maintenance period, where the applied electrical load is variable.

EXAMPLE Providing electrical power where there is no utility electrical power available or the utility electrical supply is uncertain.

#### 6.1.4 Limited time operation at constant load

Limited time operation at constant load is defined as operation of a generating set within set time limits where the applied electrical load is constant.

EXAMPLE Peak shaving load management where a generating set operating in parallel with a utility supply takes a constant load during periods of peak power consumption.

### 6.1.5 Limited time operation at varying load

Limited time operation at varying load is defined as operation of a generating set within set time limits where the applied electrical load is variable.

EXAMPLE To provide a basic support function to a building electrical supply in the event of normal utility supply failure.

## 6.2 Site criteria

### 6.2.1 Land use

Land use applies to generating sets either fixed, transportable or mobile which are used on land.

### 6.2.2 Marine use

Marine use applies to generating sets used on board ships and offshore installations.

## 6.3 Single and parallel operation

### 6.3.1 General

Generating sets may have two types of operation as follows:

#### a) Single Operation:

This applies to generating sets, irrespective of their configuration or mode of start-up and control, which will operate as the sole source of electrical power;

#### b) Parallel Operation:

This refers to the electrical connection of a generating set to another source of electrical supply with the same voltage, frequency and phase to share the power supply demand for the connected network. The characteristics of the normal utility electrical power supply, including voltage range and variation, frequency, impedance of the network, etc., shall be stated by the customer.

### 6.3.2 Generating set parallel operation

In this type of operation, two or more generating sets are electrically connected (not mechanically connected) after having been brought into synchronism. Generating sets with different outputs and speeds can be used.

### 6.3.3 Generating set operation in parallel with a utility supply

In this type of operation, one or more generating sets operating in parallel (as described in 6.3.1) are electrically connected to a utility supply.

In the case of public utility electrical power supply, permission for parallel operation has to be obtained from the public utility electricity authority. Protective equipment has to be provided in accordance with the public regulations in force at the time.

NOTE This also applies to generating sets which, in order to periodically check their start-up function, have to operate by supplying power into the normal electrical power supply system for a time period laid down by the generating set manufacturer.

## **6.4 Modes of start-up and control**

### **6.4.1 General**

The modes of start-up and control involved in the operation of a generating set are normally:

- a) starting;
- b) monitoring;
- c) voltage and frequency adjustment and synchronization where applicable;
- d) switching;
- e) stopping.

These can be fully or partly manual, or automatic (see ISO 8528-4).

### **6.4.2 Manual operation**

Manual operation applies to generating sets which are started and controlled manually.

### **6.4.3 Semi-automatic operation**

Semi-automatic operation applies to generating sets in which some of its functions are started and controlled manually and the remainder automatically.

### **6.4.4 Automatic operation**

Automatic operation applies to generating sets which are started and controlled completely automatically.

## **6.5 Start-up time**

### **6.5.1 General**

The start-up time is defined as the elapsed time between the instant when power is first demanded and the instant when it is first available. The start-up time is usually specified in seconds. The start-up time shall meet the requirement of the particular application in which the generating set is being used.

### **6.5.2 Generating set with no specified start-up time**

This is a generating set where, due to the conditions under which it operates, the start-up time is of no importance. Such generating sets are normally started manually.

### **6.5.3 Generating set with a specified start-up time**

This is a generating set where the start-up time is specified. Such generating sets are normally started automatically. Such generating sets may be further classified as follows:

#### **6.5.3.1 Long-break**

This is a generating set with a specified start-up time. The elapsed time between power supply failure and power from the generating set becoming available is fairly long. In this case, the entire generating set is started from the stationary condition after electrical power is demanded.

### 6.5.3.2 Short-break

This is a generating set operating with rotating electrical machines where the electrical power supply is interrupted for a specific time (usually defined in milliseconds) while the necessary electrical transfer takes place. A source of stored mechanical energy is used to supply power to the rotating electrical machines for a short period and, where necessary, to start and accelerate the RIC engine.

### 6.5.3.3 No-break

This is a generating set operating with continuously running electrical machines so as to ensure an uninterrupted supply of electrical power in the event of utility failure. A source of stored mechanical energy is used to supply power to the connected equipment for a short period and, where necessary, to start and accelerate the RIC engine. As the drive is transferred from one power source to another, there may be a temporary deviation in frequency.

**NOTE** It is essential that the size of the permitted deviation in frequency during the transfer is agreed between the customer and manufacturer.

## 7 Performance classes

Four performance classes are defined in order to cover the various requirements of the supplied electrical systems as follows:

### a) Class G1

This applies to generating set applications where the connected loads are such that only basic parameters of voltage and frequency need to be specified.

**EXAMPLE** General-purpose applications (lighting and other simple electrical loads).

### b) Class G2

This applies to generating set applications where its voltage characteristics are very similar to those for the commercial public utility electrical power system with which it operates. When load changes occur, there may be temporary but acceptable deviations of voltage and frequency.

**EXAMPLE** Lighting systems, pumps, fans and hoists.

### c) Class G3

This applies to applications where the connected equipment makes severe demands on the stability and level of the frequency, voltage and waveform characteristics of the electrical power supplied by the generating set.

**EXAMPLE** Telecommunications and thyristor-controlled loads. It should be remembered that both rectifier and thyristor-controlled loads may need special consideration with respect to their effect on generator-voltage waveform.

### d) Class G4

This applies to applications where the demands made on the stability and level of the frequency, voltage and waveform characteristics of the electrical power supplied by the generating set are exceptionally severe.

**EXAMPLE** Data-processing equipment or computer systems.

## 8 Installation features

### 8.1 General

Requirements to meet local regulations may affect the design and installation of the generating set and shall be taken into account by the customer and manufacturer in addition to the requirements shown in 8.2 to 8.6.

### 8.2 Installation configurations

#### 8.2.1 General

The installation configurations in 8.2.2 to 8.2.4 may or may not have all the necessary generating set auxiliary equipment integrally mounted.

#### 8.2.2 Fixed

This configuration applies to generating sets which are permanently installed.

#### 8.2.3 Transportable

This configuration applies to generating sets which are not permanently installed or are mobile.

#### 8.2.4 Mobile

This configuration applies to generating sets which have an integral chassis fitted with wheels whereby the generating set can be moved from one location to another.

### 8.3 Generating set configurations

In order to simplify the contractual information required for specifying RIC engine driven generating set applications, application configurations are as follows:

- A: without baseframe;
- B: with baseframe;
- C: with baseframe, integrally mounted controlgear, switchgear and auxiliaries;
- D: configuration as given in C with enclosure (see Clause 9);
- E: configuration as given in C having an integral set of wheels or mounted on a trailer (see 8.2.4).

### 8.4 Mounting types

The type of mounting to be used for the generating set shall be agreed between the customer and the generating set manufacturer. Some typical types of mounting are:

#### a) Rigid:

In this type of installation, the generating set is installed on inflexible mounts. If foundations for mounting the generating set are installed on substrates of low elasticity (e.g. cork tiles) with no resilient layers inserted, the method of mounting is considered to be rigid.

#### b) Resilient:

In this type of installation, the generating set is installed on resilient mountings that are able to, depending upon their characteristics, partially insulate it from vibration. For special applications (e.g. marine or mobile) restrained resilient mountings may be required.

1) Fully resilient:

In this type of installation, the generating set is mounted on a baseframe or a foundation fitted with mountings that provide insulation against vibration to a high level as agreed between the manufacturer and the customer.

2) Semi-resilient:

In this type of installation, the RIC engine is mounted resiliently and the electrical generator is mounted rigidly on a baseframe or foundation.

c) Mounting on resilient foundation:

In this type of installation, the generating set is mounted on a resilient foundation (damping mass) which is isolated from the load-bearing foundation by, for example, anti-vibration mounts.

## **8.5 Connection between the RIC engine and electrical generator**

### **8.5.1 General**

The mechanical connection between the RIC engine and the electrical generator is determined by the level of power to be transmitted and the configuration of the installation. It is affected by such parameters as the design of the engine, design of the generator, mounting type, the power to be transmitted, speed of rotation, out-of-balance requirements and whether a gearbox is used.

### **8.5.2 Coupling arrangements**

Typical coupling arrangements are rigid, torsionally rigid, flexible, torsionally flexible or through a clutch.

### **8.5.3 Assembly arrangements**

The assembly between the RIC engine and the electrical generator may be with or without the use of a flange housing.

## **8.6 Additional installation features — Weather effects**

### **8.6.1 Inside installation**

In this type of installation, the generating set is installed in a closed environment where it is not exposed to the direct effects of the weather. Careful consideration shall be given to the maximum and minimum temperatures expected in the operating environment.

### **8.6.2 Outside installation with protection from weather**

In this type of installation, the generating set is installed in an environment where it may be partially exposed to the direct effects of the weather. The generating set may be installed in a closed, but not permanent, protective enclosure or under a protective roof.

### **8.6.3 Open-air installation**

In this type of installation, the generating set is installed in an environment which is fully exposed to the direct effects of the weather.

## 9 Emissions

When a generating set operates, it produces various emissions including noise, vibration, heat, gas and electromagnetic disturbance.

Any applicable legislation relating to the protection of the environment and to the health and safety of personnel operating or maintaining the generating set shall be taken into account by the manufacturer and customer at the time of agreeing to the performance specification.

## 10 Standard reference conditions

For the purpose of determining the rated power output of the generating set, the following standard reference conditions shall be used:

- Total barometric pressure:  $p_r = 100 \text{ kPa}$ ;
- Air ambient temperature:  $T_r = 298 \text{ K}$  ( $t_r = 25 \text{ °C}$ );
- Relative humidity:  $\phi_r = 30 \%$ .

## 11 Site conditions

### 11.1 General

The site conditions under which a generating set is required to operate may affect certain characteristics and shall be taken into account by the customer and manufacturer when agreeing to the contract.

The prevailing site conditions shall be clearly specified by the customer and any particular hazardous conditions (e.g. explosive atmospheres or flammable gases) shall be described. Such characteristics may include but are not limited to those indicated in 11.2 to 11.10.

### 11.2 Ambient temperature

The customer shall inform the manufacturer of the upper and the lower ambient temperature limits at the site where the generating set will be installed and operated.

### 11.3 Altitude

The customer shall inform the manufacturer of the altitude above sea level of the site where the generating set will be installed and operated. However, it is preferable to provide the typical upper and lower limits of the barometric pressure experienced on site.

### 11.4 Humidity

The customer shall inform the manufacturer of the typical upper and lower values of humidity related to the temperature and pressure experienced on site (see 11.2 and 11.3).

### 11.5 Air quality

The customer shall inform the manufacturer if the generating set is required to operate in a polluted atmosphere (e.g. sand or dust). Special requirements may have to be applied in order to obtain satisfactory generating set performance and operation. Any increased maintenance requirements necessary to ensure trouble-free generating set operation due to these conditions should be noted by the customer.



### **11.6 Marine environment**

Special consideration is necessary when generating sets are required to operate in a marine environment. This may also apply to generating sets on land but installed and operated at a coastal site. The ambient environment of the generating set installation area shall be clearly defined by the customer.

### **11.7 Shock and imposed vibration**

It shall be clearly stated by the customer if the generating set is required to operate under conditions where external shock and/or vibration may occur (e.g. in an earthquake area or where externally imposed vibration from an adjacent source is possible).

### **11.8 Chemical pollution**

If the generating set is required to operate under conditions where chemical pollution exists, the nature and extent of the pollution shall be clearly stated by the customer.

### **11.9 Radiation**

Various kinds of radiation may affect components of the generating set. As a result some components/assemblies may need special protection and/or a special maintenance programme in order to ensure trouble-free operation. The nature and extent of the radiation shall be clearly stated by the customer.

### **11.10 Cooling water/liquid**

If the generating set has water/liquid cooled heat exchangers, the customer shall state the minimum and maximum temperatures (and, where necessary, the chemical composition and quantity) of the secondary (external) transfer liquid provided.

## **12 Power adjustment for operating conditions**

To determine the appropriate generating set power ratings, the customer shall specify the operating conditions prevailing at the site as follows:

- a) the barometric pressure (highest and lowest readings available or, if no pressure data are available, the altitude above sea level);
- b) the monthly mean, minimum and maximum air temperatures during the hottest and coldest months of the year;
- c) the highest and lowest ambient air temperatures around the engine;
- d) the relative humidity (or alternatively the water vapour pressure or the wet and dry bulb temperature) ruling at the maximum temperature conditions;
- e) the maximum and minimum temperatures of the cooling water available.

Where the site operating conditions differ from the standard reference conditions given in Clause 10, any necessary adjustment to the generating set power shall be made in order to determine the site rated power of the generating set.

For generating sets that are to be installed on board ships and intended for unrestricted service in accordance with the International Association of Classification Societies (IACS) requirements, the rated power shall be based on the nominal ambient conditions as specified in ISO 3046-1.

### 13 Power rating definitions

#### 13.1 General

The power of the generating set is the power output available for consumer loads at the generating set terminals excluding the electrical power absorbed by the essential independent auxiliaries (see 5.1 of ISO 8528-2 and Clause 5 of ISO 8528-3)

#### 13.2 Power ratings

Generating set power ratings shall be expressed in kilowatts (kW) at its rated frequency and a power factor ( $\cos \varphi$ ) of 0,8 lagging unless otherwise stated.

Generating set power rating categories are necessary for inclusion in the manufacturer's declaration of the power which the generating set will deliver under the agreed installation and operating conditions.

The power rating categories declared by the generating set manufacturer shall be used. No other category shall be used unless agreed between the customer and manufacturer.

#### 13.3 Power rating categories

The generating set manufacturer shall be responsible for determining the power output in accordance with the requirements of 13.3.1 to 13.3.4 (see Figures 1 to 4) and recognizing the maintenance schedules and service procedures specified by the engine, a.c. generator and controlgear and switchgear manufacturers.

NOTE The user should be made aware that if any of the conditions regarding power output are not fulfilled, the generating set life will be reduced.

##### 13.3.1 Continuous Power (COP)

Continuous power is defined as being the maximum power which the generating set is capable of delivering continuously whilst supplying a constant electrical load when operated for an unlimited number of hours per year under the agreed operating conditions with the maintenance intervals and procedures being carried out as prescribed by the manufacturer (see Figure 1).

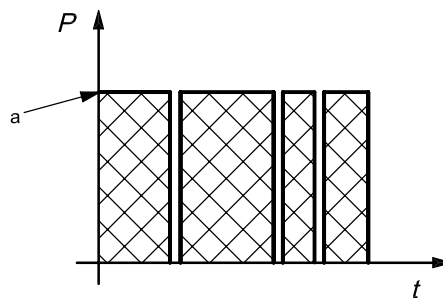

**Key**

- $t$  time
- $P$  power

a Continuous Power (100%).

**Figure 1 — Illustration of COP**

**13.3.2 Prime Power (PRP)**

Prime power is defined as being the maximum power which a generating set is capable of delivering continuously whilst supplying a variable electrical load when operated for an unlimited number of hours per year under the agreed operating conditions with the maintenance intervals and procedures being carried out as prescribed by the manufacturer (see Figure 2).

The permissible average power output ( $P_{pp}$ ) over 24 h of operation shall not exceed 70 % of the PRP unless otherwise agreed by the RIC engine manufacturer.

NOTE For applications requiring a permissible  $P_{pp}$  higher than stated, a continuous power COP rating should be used.

When determining the actual average power output ( $P_{pa}$ ) (see Figure 2) of a variable power sequence, powers of less than 30 % of the PRP shall be taken as 30 % and time at standstill shall not be counted.

The actual average power ( $P_{pa}$ ) is calculated as follows:

$$P_{pa} = \frac{P_1t_1 + P_2t_2 + P_3t_3 + \dots + P_nt_n}{t_1 + t_2 + t_3 + \dots + t_n} = \frac{\sum_{i=1}^n P_i t_i}{\sum_{i=1}^n t_i}$$

where  $P_1, P_2 \dots P_i$  is the power at time  $t_1, t_2 \dots t_i$ .

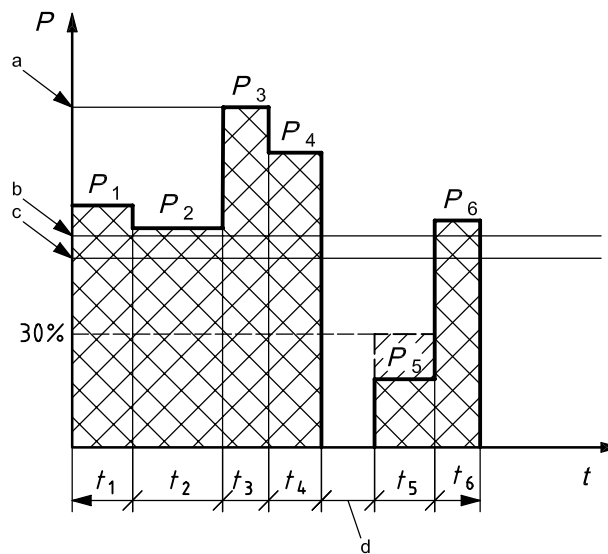

**Key**

- $t$  time
- $P$  power
- a Prime Power (100 %).
- b Permissible average power during a 24 h period ( $P_{pp}$ ).
- c Actual average power over a 24 h period ( $P_{pa}$ ).
- d Stop.

NOTE  $t_1 + t_2 + t_3 + \dots + t_n = 24$  h.

**Figure 2 — Illustration of PRP**

**13.3.3 Limited-Time running Power (LTP)**

Limited-time running power is defined as the maximum power available, under the agreed operating conditions, for which the generating set is capable of delivering for up to 500 h of operation per year with the maintenance intervals and procedures being carried out as prescribed by the manufacturers (see Figure 3).

NOTE Limited time running power at 100 % is limited to a maximum of 500 h per year.

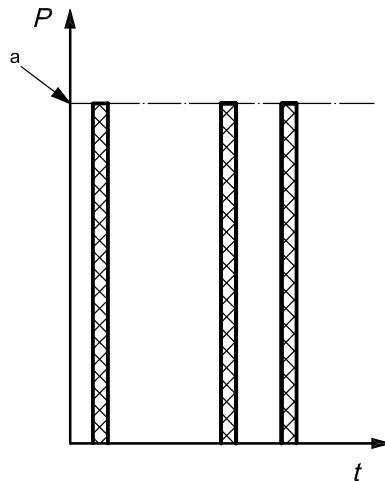

**Key**

*t* time

*P* power

a Limited time running power (100%).

**Figure 3 — Illustration of LTP**

**13.3.4 Emergency Standby Power (ESP)**

Emergency standby power is defined as the maximum power available during a variable electrical power sequence, under the stated operating conditions, for which a generating set is capable of delivering in the event of a utility power outage or under test conditions for up to 200 h of operation per year with the maintenance intervals and procedures being carried out as prescribed by the manufacturers (see Figure 4).

The permissible average power output ( $P_{pp}$ ) (see Figure 4) over 24 h of operation shall not exceed 70 % of the ESP unless otherwise agreed by the RIC engine manufacturer.

The actual average power output ( $P_{pa}$ ) shall be below or equal to the permissible average power output ( $P_{pp}$ ) defined for ESP.

When determining the actual average power output ( $P_{pa}$ ) of a variable power sequence, powers of less than 30 % of the ESP shall be taken as 30 % and time at standstill shall not be counted.

The actual average power ( $P_{pa}$ ) is calculated as follows:

$$P_{pa} = \frac{P_1t_1 + P_2t_2 + P_3t_3 + \dots + P_nt_n}{t_1 + t_2 + t_3 + \dots + t_n} = \frac{\sum_{i=1}^n P_i t_i}{\sum_{i=1}^n t_i}$$

where  $P_1, P_2 \dots P_i$  is the power at time  $t_1, t_2 \dots t_i$ .

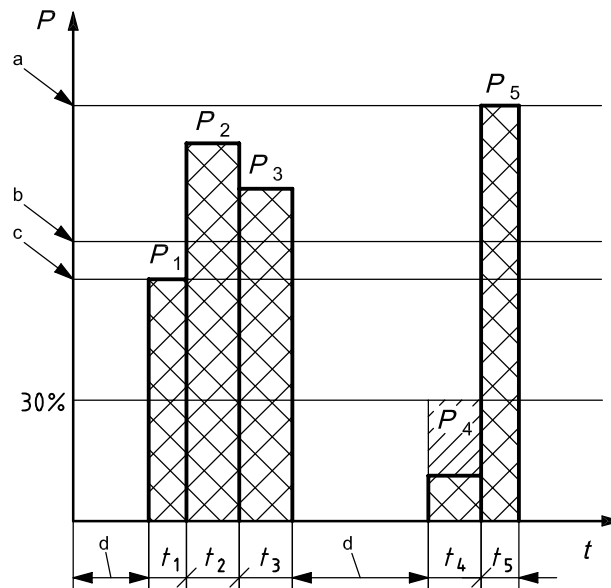

### Key

$t$  time

$P$  power

a Emergency Standby Power (100%).

b Permissible average power during a 24 h period ( $P_{pp}$ ).

c Actual average power over a 24 h period ( $P_{pa}$ ).

d Stop.

NOTE  $t_1 + t_2 + t_3 + \dots + t_n = 24 \text{ h}$

Figure 4 — Illustration of ESP

## 14 Operating performance

### 14.1 Starting temperature

The RIC engine manufacturer shall state the minimum temperature at which the generating set will start with the installed starting system.

### 14.2 Load acceptance

When load is suddenly applied to a generating set, there will be a transient deviation in the output voltage and frequency. The magnitude of these deviations will depend both on the magnitude of the active power (in kilowatts) and reactive power (in kilovars) changes, relative to the total available electrical capacity and to the dynamic characteristics of the generating set (see ISO 8528-2 and ISO 8528-5).

If load acceptance capability is an important requirement, then it shall be clearly stated by the customer.

### 14.3 Cyclic irregularity

The rotational irregularity imposed on the generator by the RIC engine combustion process may cause modulation of the output voltage (see Clauses 3 and 10 of ISO 8528-5).

#### **14.4 Generator temperature rise**

The generator winding temperature rise may be an important factor in limiting the long-term reliability of the generating set.

An increase in allowable temperature rise may be possible if the generating set is to be used on a limited time basis (see 6.2 of ISO 8528-3).

#### **14.5 Fuel and lubricating oil characteristics and consumption**

The manufacturer shall state the characteristics and consumption of fuel and lubricating oil to be used in the generating set. If verification of fuel consumption is required, the method of measurement shall be agreed between the customer and manufacturer, as outlined in ISO 3046-1.

Statements of generating set fuel consumption shall be made with reference to the electrical power available at the output terminals, taking into account the electrical power required for driving the essential independent auxiliaries (see ISO 3046-1) and the power loss in the a.c. generator for a given power and power factor. The lower calorific value of the fuel shall be stated.

#### **14.6 Minimum running hours**

The capacity of fuel and lubricating oil tanks may impose a limit on generating set running time.

Where such tanks are provided, the manufacturer shall state the generating set minimum running time without fuel and lubricating oil tank replenishment.

#### **14.7 Regulation**

##### **14.7.1 Frequency regulation**

The steady-state and transient electrical frequency regulation requirements may be an important consideration when specifying generating set performance. If this is the case, then it shall be clearly stated by the customer.

##### **14.7.2 Voltage regulation**

It is necessary to consider both steady-state and transient voltage regulation when specifying a generating set. It must also be noted that the nature of the electrical load current waveform imposed on the generating set may affect the output voltage waveform and steady-state voltage accuracy. If voltage regulation is an important requirement, it shall be clearly stated by the customer.

## Bibliography

- [1] ISO 15550:2002, *Internal combustion engines — Determination and method for the measurement of engine power — General requirements*



**NATIONAL ANNEX A**  
*(National Foreword)*

**A-1 BIS CERTIFICATION MARKING**

RIC engine driven ac generating set may also be marked with the Standard Mark.

**A-1.1** The use of the Standard Mark is governed by the provisions of the *Bureau of Indian Standards Act, 1986* and the Rules and Regulations made thereunder. The details of conditions under which the licence for the use of the Standard Mark may be granted to manufacturers or producers may be obtained from the Bureau of Indian Standards.

*(Continued from second cover)*

For the purpose of deciding whether a particular requirement of this standard is complied with, the final value, observed or calculated, expressing the result of a test or analysis, shall be rounded off in accordance with IS 2:1960 'Rules for rounding off numerical values (*revised*)'. The number of significant places retained in the rounded off value should be the same as that of the specified value in this standard.

## Bureau of Indian Standards

BIS is a statutory institution established under the *Bureau of Indian Standards Act, 1986* to promote harmonious development of the activities of standardization, marking and quality certification of goods and attending to connected matters in the country.

### Copyright

BIS has the copyright of all its publications. No part of these publications may be reproduced in any form without the prior permission in writing of BIS. This does not preclude the free use, in course of implementing the standard, of necessary details, such as symbols and sizes, type or grade designations. Enquiries relating to copyright be addressed to the Director (Publications), BIS.

### Review of Indian Standards

Amendments are issued to standards as the need arises on the basis of comments. Standards are also reviewed periodically; a standard along with amendments is reaffirmed when such review indicates that no changes are needed; if the review indicates that changes are needed, it is taken up for revision. Users of Indian Standards should ascertain that they are in possession of the latest amendments or edition by referring to the latest issue of 'BIS Catalogue' and 'Standards: Monthly Additions'.

This Indian Standard has been developed from Doc No.: TED 2 (773).

#### Amendments Issued Since Publication

Amendment No.	Date of Issue	Text Affected

#### BUREAU OF INDIAN STANDARDS

##### Headquarters:

Manak Bhavan, 9 Bahadur Shah Zafar Marg, New Delhi 110002

Telephones: 2323 0131, 2323 3375, 2323 9402

Website: [www.bis.org.in](http://www.bis.org.in)

##### Regional Offices:

Telephones

Central : Manak Bhavan, 9 Bahadur Shah Zafar Marg NEW DELHI 110002	{ 2323 7617 2323 3841
Eastern : 1/14, C.I.T. Scheme VII M, V.I.P. Road, Kankurgachi KOLKATA 700054	{ 2337 8499, 2337 8561 2337 8626, 2337 9120
Northern : SCO 335-336, Sector 34-A, CHANDIGARH 160022	{ 260 3843 260 9285
Southern : C.I.T. Campus, IV Cross Road, CHENNAI 600113	{ 2254 1216, 2254 1442 2254 2519, 2254 2315
Western : Manakalaya, E9 MIDC, Marol, Andheri (East) MUMBAI 400093	{ 2832 9295, 2832 7858 2832 7891, 2832 7892

**Branches:** AHMEDABAD. BANGALORE. BHOPAL. BHUBANESHWAR. COIMBATORE. DEHRADUN. FARIDABAD. GHAZIABAD. GUWAHATI. HYDERABAD. JAIPUR. KANPUR. LUCKNOW. NAGPUR. PARWANOO. PATNA. PUNE. RAJKOT. THIRUVANATHAPURAM. VISAKHAPATNAM.